

**Features**

- 1-channel isolated barrier
- 115 V AC supply
- Dry contact or NAMUR inputs
- Relay contact output
- Line fault detection (LFD)
- Reversible mode of operation
- Up to SIL 2 acc. to IEC 61508/IEC 61511

**Function**

This isolated barrier is used for intrinsic safety applications. It transfers digital signals (NAMUR sensors/mechanical contacts) from a hazardous area to a safe area.

The proximity sensor or switch controls a form C changeover relay contact for the safe area load. The barrier output changes state when the input signal changes state. The normal output state can be reversed using switch S1. Switch S3 is used to enable or disable line fault detection of the field circuit.

During an error condition, relays revert to their de-energized state and LEDs indicate the fault according to NAMUR NE44.

**Assembly**

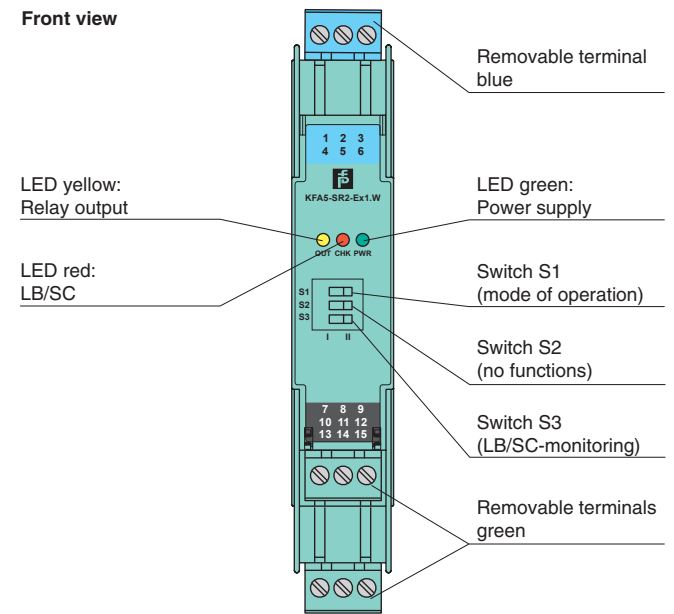

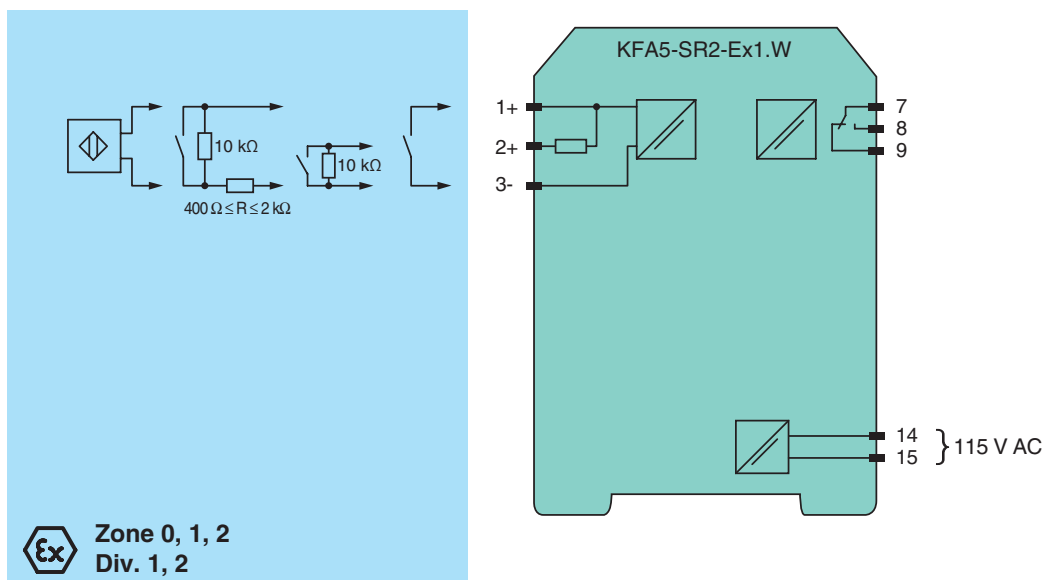

**Connection**



Release date 2019-01-24 13:56 Date of issue 2019-01-24 103371\_eng.xml

Refer to "General Notes Relating to Pepperl+Fuchs Product Information".

<b>General specifications</b>		
Signal type		Digital Input
<b>Functional safety related parameters</b>		
Safety Integrity Level (SIL)		SIL 2
<b>Supply</b>		
Connection		terminals 14, 15
Rated voltage	$U_r$	103.5 ... 126 V AC , 45 ... 65 Hz
Power consumption		1 W
<b>Input</b>		
Connection side		field side
Connection		terminals 1+, 2+, 3-
Rated values		acc. to EN 60947-5-6 (NAMUR)
Open circuit voltage/short-circuit current		approx. 8 V DC / approx. 8 mA
Switching point/switching hysteresis		1.2 ... 2.1 mA / approx. 0.2 mA
Line fault detection		breakage $I \leq 0.1$ mA , short-circuit $I > 6$ mA
Pulse/Pause ratio		$\geq 20$ ms / $\geq 20$ ms
<b>Output</b>		
Connection side		control side
Connection		terminals 7, 8, 9
Output		signal, relay
Contact loading		253 V AC/2 A/cos $\phi > 0.7$ ; 126.5 V AC/4 A/cos $\phi > 0.7$ ; 40 V DC/2 A resistive load
Energized/De-energized delay		approx. 20 ms / approx. 20 ms
Mechanical life		$10^7$ switching cycles
<b>Transfer characteristics</b>		
Switching frequency		< 10 Hz
<b>Galvanic isolation</b>		
Input/Output		reinforced insulation according to IEC/EN 61010-1, rated insulation voltage 300 V <sub>eff</sub>
Input/power supply		reinforced insulation according to IEC/EN 61010-1, rated insulation voltage 300 V <sub>eff</sub>
Output/power supply		reinforced insulation according to IEC/EN 61010-1, rated insulation voltage 300 V <sub>eff</sub>
<b>Indicators/settings</b>		
Display elements		LEDs
Control elements		DIP-switch
Configuration		via DIP switches
Labeling		space for labeling at the front
<b>Directive conformity</b>		
Electromagnetic compatibility		
Directive 2014/30/EU		EN 61326-1:2013 (industrial locations)
Low voltage		
Directive 2014/35/EU		EN 61010-1:2010
<b>Conformity</b>		
Electromagnetic compatibility		NE 21:2006
Degree of protection		IEC 60529:2001
Input		EN 60947-5-6:2000
<b>Ambient conditions</b>		
Ambient temperature		-20 ... 60 °C (-4 ... 140 °F)
<b>Mechanical specifications</b>		
Degree of protection		IP20
Connection		screw terminals
Mass		approx. 150 g
Dimensions		20 x 119 x 115 mm (0.8 x 4.7 x 4.5 inch) , housing type B2
Mounting		on 35 mm DIN mounting rail acc. to EN 60715:2001
<b>Data for application in connection with hazardous areas</b>		
EU-Type Examination Certificate		PTB 00 ATEX 2081
Marking		 II (1)G [Ex ia Ga] IIC  II (1)D [Ex ia Da] IIIC  I (M1) [Ex ia Ma] I
Input		Ex ia
Voltage	$U_o$	10.6 V
Current	$I_o$	19.1 mA
Power	$P_o$	51 mW (linear characteristic)
<b>Supply</b>		
Maximum safe voltage	$U_m$	126.5 V AC (Attention! $U_m$ is no rated voltage.)
<b>Output</b>		
Contact loading		253 V AC/2 A/cos $\phi > 0.7$ ; 126.5 V AC/4 A/cos $\phi > 0.7$ ; 40 V DC/2 A resistive load

Release date 2019-01-24 13:56 Date of issue 2019-01-24 103371\_eng.xml

Refer to "General Notes Relating to Pepperl+Fuchs Product Information".

Maximum safe voltage	$U_m$	253 V AC (Attention! The rated voltage can be lower.)
Galvanic isolation		
Input/Output		safe electrical isolation acc. to IEC/EN 60079-11, voltage peak value 375 V
Input/power supply		safe electrical isolation acc. to IEC/EN 60079-11, voltage peak value 375 V
Directive conformity		
Directive 2014/34/EU		EN 60079-0:2012+A11:2013 , EN 60079-11:2012
<b>International approvals</b>		
FM approval		
Control drawing		116-0035
UL approval		
Control drawing		116-0145
CSA approval		
Control drawing		116-0047
IECEX approval		IECEX PTB 11.0031
Approved for		[Ex ia Ga] IIC, [Ex ia Da] IIIC, [Ex ia Ma] I
<b>General information</b>		
Supplementary information		Observe the certificates, declarations of conformity, instruction manuals, and manuals where applicable. For information see <a href="http://www.pepperl-fuchs.com">www.pepperl-fuchs.com</a> .

Release date 2019-01-24 13:56 Date of issue 2019-01-24 103371\_eng.xml

Refer to "General Notes Relating to Pepperl+Fuchs Product Information".

Pepperl+Fuchs Group  
www.pepperl-fuchs.com

USA: +1 330 486 0002  
pa-info@us.pepperl-fuchs.com

Germany: +49 621 776 2222  
pa-info@de.pepperl-fuchs.com

Singapore: +65 6779 9091  
pa-info@sg.pepperl-fuchs.com

**Configuration**

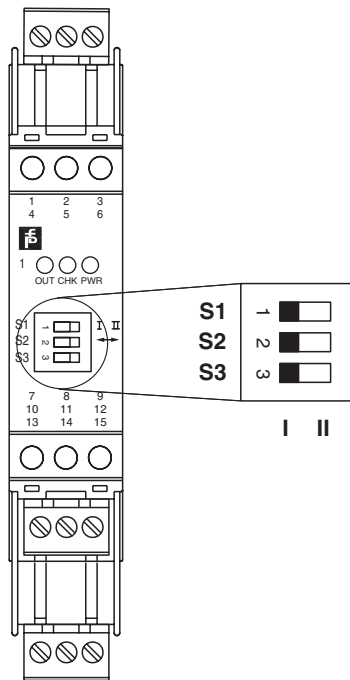

**Switch position**

S	Function		Position
1	Mode of operation Output I (relay) energized	with high input current	I
		with low input current	II
2	no function		
3	Line fault detection	ON	I
		OFF	II

**Operating status**

Control circuit	Input signal
Initiator high impedance/ contact opened	low input current
Initiator low impedance/ contact closed	high input current
Lead breakage, lead short-circuit	Line fault

Factory settings: switch 1, 2 and 3 in position I

**Maximum switching power of output contacts**

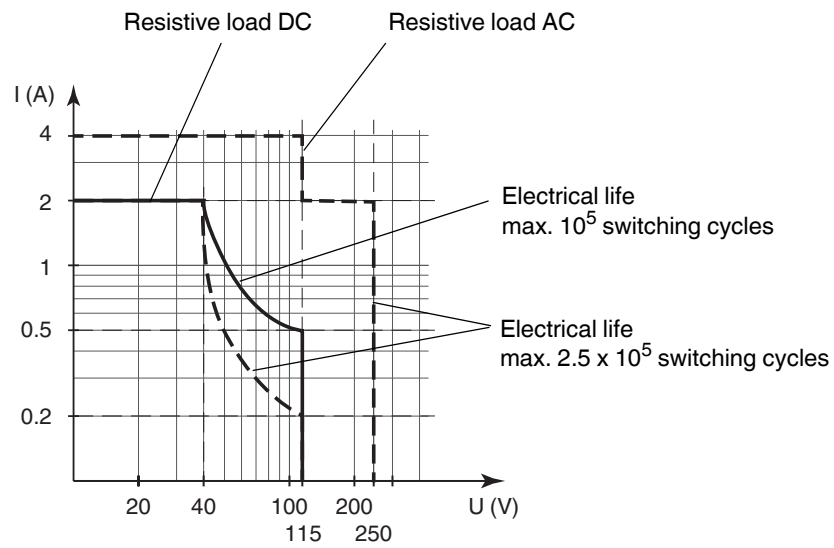

The maximum number of switching cycles is depending on the electrical load and may be higher when reduced currents and voltages are applied.