



Product information

Separating and protective instruments

Overvoltage arresters

B53-19

B61-300, B61-300 FI

B62-36G, B62-30W

B63-32, B63-48

B81-35



Document ID: 50707

VEGA

Contents

1 Product description 3

2 Type overview..... 4

3 Electrical connection..... 5

4 Dimensions..... 7

Take note of safety instructions for Ex applications



Please note the Ex specific safety information which you can find on our homepage www.vega.com/downloads under "Approvals" and which comes with every instrument. In hazardous areas you should take note of the corresponding regulations, conformity and type approval certificates of the sensors and power supply units. The sensors must only be operated on intrinsically safe circuits. The permissible electrical values are stated in the certificate.

1 Product description

Overvoltage arresters limit interference and overvoltages in industrial system to uncritical values so that failures and malfunctions of connected instruments cannot occur.

An overvoltage arrester can be used on both sides of the circuit. It is e.g. mounted on a carrier rail near the sensor, directly in the cable entry, or near the controller, PLC or control system. This way, the field side as well as the processing side are protected in case of voltage surges.

The following circuit diagram shows the electrical configuration of an overvoltage arrester.

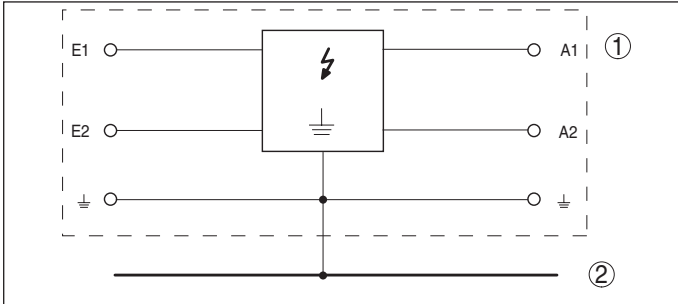

Fig. 1: Simplified circuit diagram with an overvoltage arrester, in this case a B62-36G

- 1 Overvoltage arrester
- 2 Potential equalisation

This product information booklet gives you an overview and helps you select the right overvoltage arrester.

Overvoltage arrester for carrier rail mounting

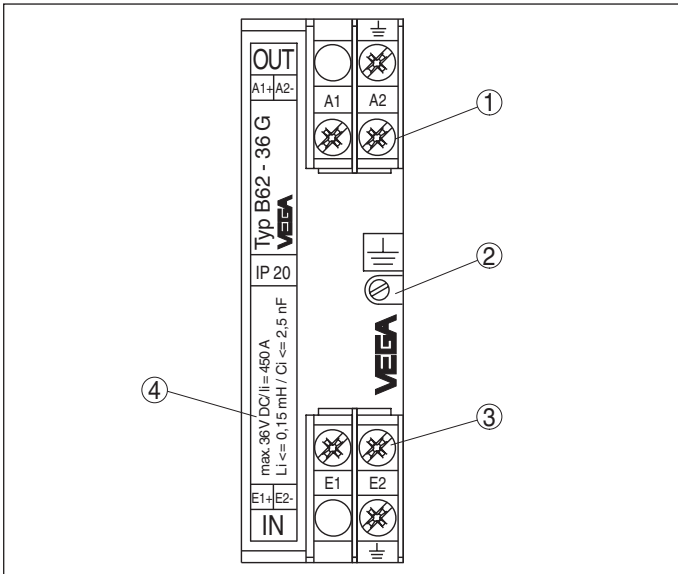

Fig. 2: Configuration of an overvoltage arrester for carrier rail mounting, in this case a B62-36G

- 1 Terminals "Out" (protected side)
- 2 Screw for carrier rail fastening
- 3 Terminals "In" (unprotected side)
- 4 Type label

Overvoltage arrester B53-19

The B53-19 is an overvoltage arrester for the measuring cable of conductive probes.

Overvoltage arrester B61-300

The B61-300 is an overvoltage arrester for sensors and controllers with mains voltage supply.

Overvoltage arrester B61-300 FI

The B61-300 FI is an overvoltage arrester for sensors and controllers with mains power supply connected via a fault-current circuit breaker (FI).

Overvoltage arrester B62-30W

The B62-30W is an overvoltage arrester for supply and control cables for Profibus PA instruments.

Overvoltage arrester B62-36G

The B62-36G is an overvoltage arrester for sensors and controllers in two-wire technology 4 ... 20 mA/HART.

Overvoltage arrester for mounting in sensor housing

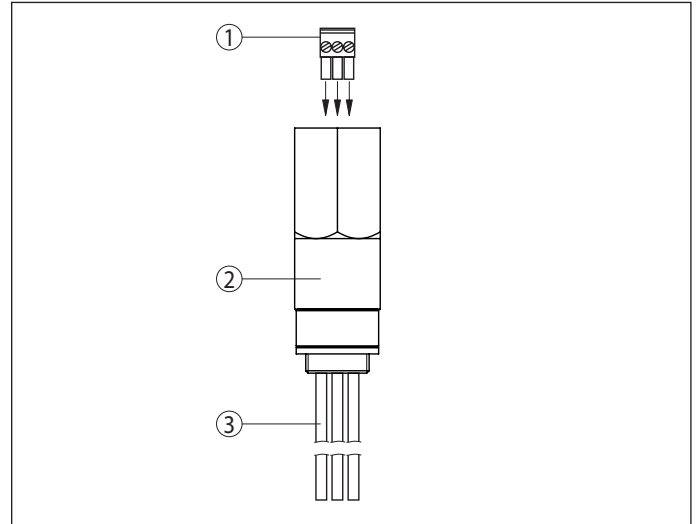

Fig. 3: Configuration of an overvoltage arrester for mounting inside the sensor housing

- 1 Terminals for the signal cable input (unprotected side)
- 2 Overvoltage protection
- 3 Signal cable output to the sensor (protected side)

Overvoltage arrester B63-32, B63-48

B63-32 and B63-48 are overvoltage arresters for installation inside the housings of VEGA level and pressure sensors.

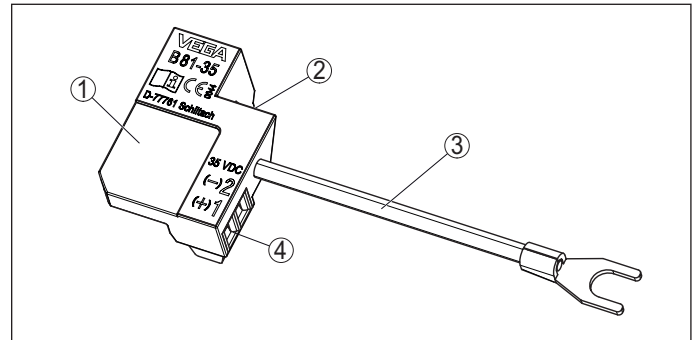

Fig. 4: Configuration, overvoltage arrester for mounting on the sensor electronics

- 1 Overvoltage protection
- 2 Plug connector to the sensor electronics (protected side)
- 3 Connection cable to ground terminal
- 4 Terminal block to the supply and signal cable (unprotected side)

Overvoltage arrester B81-35

The B81-35 is an overvoltage arrester for mounting on the electronics modules of VEGA level and pressure sensors.

2 Type overview



B53-19

B61-300

B61-300FI

B62-30W

B62-36G

Application area	Measuring cable of conductive probes	Sensors and controllers with mains voltage supply	Sensors and controllers with mains voltage supply through fault-current circuit breaker (FI)	Supply and signal cables of Profibus PA instruments	Sensors and controllers in two-wire technology 4 ... 20 mA/HART
Operating voltage	19 V	100 ... 300 V AC/DC	100 ... 300 V AC/DC	9 ... 36 V DC	9 ... 36 V DC
DC response voltage	22 V	500 V	500 V	41 V	41 V
Mounting	Carrier rail mounting				
Ambient temperature	-40 ... +60 °C (-40 ... +140 °F)				
Protection rating	IP20 (unmounted), IP65 (mounted)				
Approvals	-			ATEX, IEC	



B63-32/48



B81-35

Application area	Sensors in two-wire technology 4 ... 20 mA/HART, Profibus PA, Foundation Fieldbus	Sensors in two-wire technology 4 ... 20 mA/HART, Profibus PA, Foundation Fieldbus
Operating voltage	32 V DC/48 V DC	9 ... 35 V DC
DC response voltage	38 V/76 V	600 V -20 %/+ 35%
Mounting	In the sensor housing	On the sensor electronics
Ambient temperature	-40 ... +85 °C (-40 ... +185 °F)	-40 ... +85 °C (-40 ... +176 °F)
Protection rating	IP20 (unassembled) IP66/IP67, IP66/IP68 (0.2 bar) - mounted	
Approvals	ATEX	

3 Electrical connection

3.1 Connection B53-19

Wiring plan

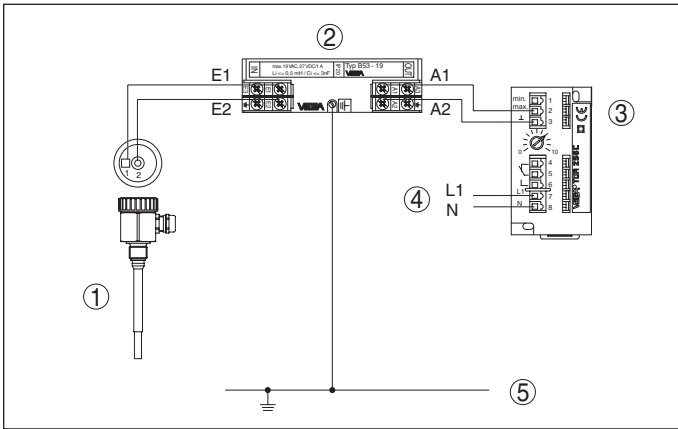

Fig. 5: Wiring plan, overvoltage arrester B53-19 with conductive single rod probe

- 1 Measuring probe
- 2 Overvoltage protection
- 3 Protected instrument (controller)
- 4 Voltage supply
- 5 Potential equalisation

3.2 Connection B61-300

Wiring plan

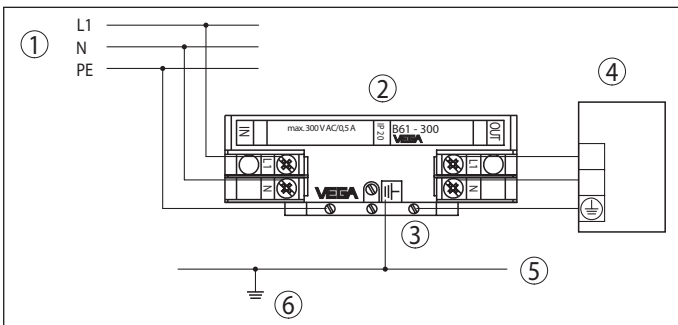

Fig. 6: Wiring plan, overvoltage arrester B61-300

- 1 Mains supply
- 2 Overvoltage protection
- 3 PE terminal
- 4 Protected instrument (e.g. controller)
- 5 Carrier rail
- 6 Potential equalisation

3.3 Connection B61-300 FI

Wiring plan

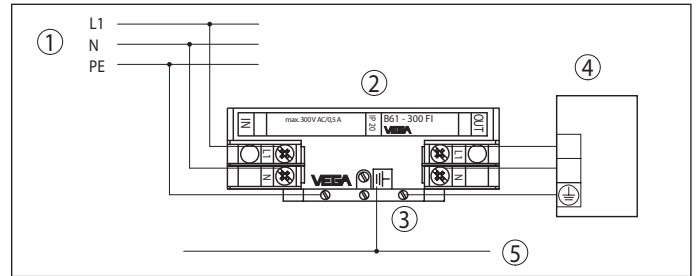

Fig. 7: Wiring plan, overvoltage arrester B61-300 FI

- 1 Mains supply through fault-current circuit breaker (FI)
- 2 Overvoltage protection
- 3 PE terminal
- 4 Protected instrument (e.g. controller)
- 5 Carrier rail

3.4 Connection B62-30W

Wiring plan

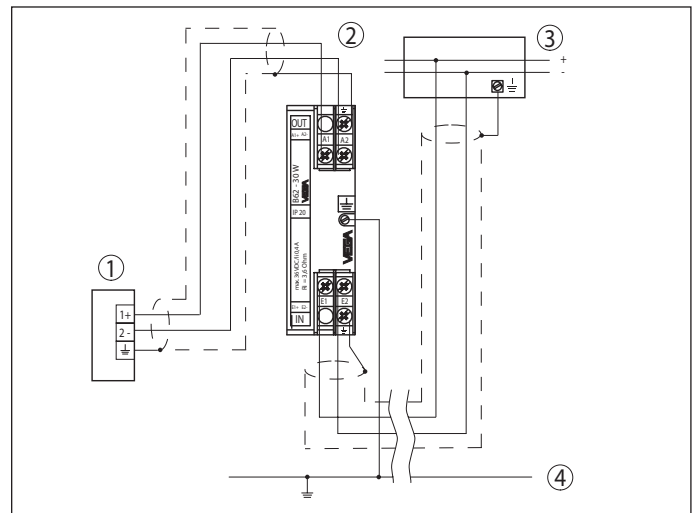

Fig. 8: Wiring plan, overvoltage arrester B62-30W

- 1 Protected instrument (sensor)
- 2 Overvoltage protection
- 3 Profibus PA System
- 4 Potential equalisation

3.5 Connection B62-36G

Wiring plan

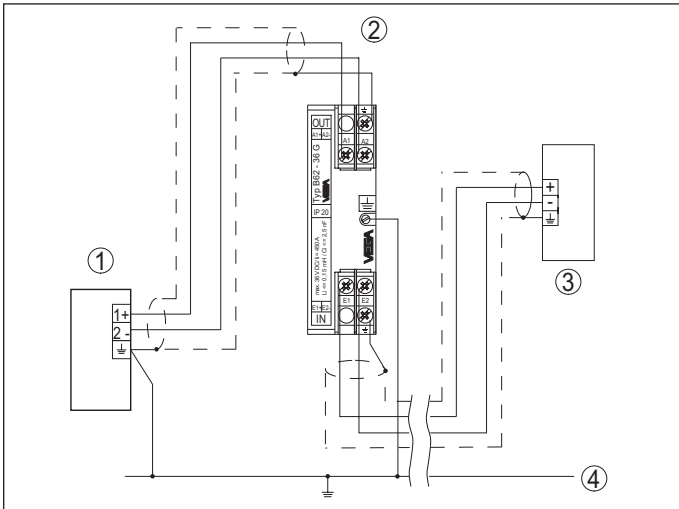

Fig. 9: Wiring plan, overvoltage arrester B62-36G

- 1 Protected instrument (sensor)
- 2 Overvoltage protection
- 3 Controller/PLC
- 4 Potential equalisation

3.6 Connection B63-32, B63-48

Wiring plan

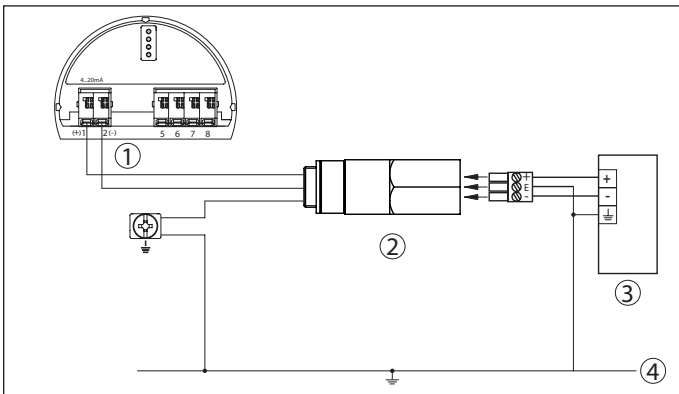

Fig. 10: Wiring plan, overvoltage arrester B63-32, B63-48

- 1 Protected instrument (sensor)
- 2 Overvoltage arrester
- 3 Controller/PLC
- 4 Potential equalisation

Terminals sensor	Wire colour/Polarity
1	Red (+)
2	Black (-)
Ground terminal	Green/Yellow

3.7 Connection B81-35

Wiring plan

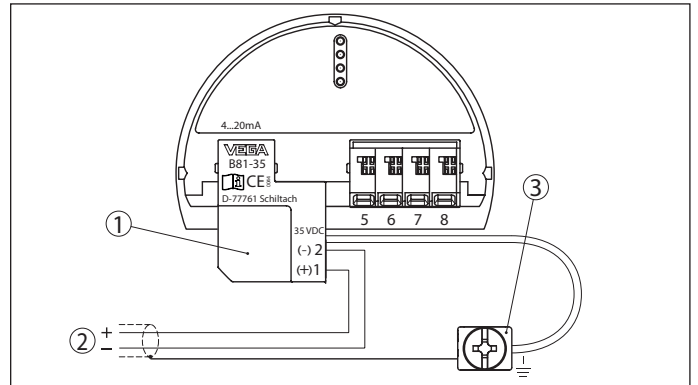

Fig. 11: Wiring plan, overvoltage arrester B81-35

- 1 Voltage supply/Signal output
- 2 Overvoltage protection
- 3 Ground terminal for connection of the cable screen and the connection cable of the overvoltage protection module

4 Dimensions

Overvoltage arrester for carrier rail mounting

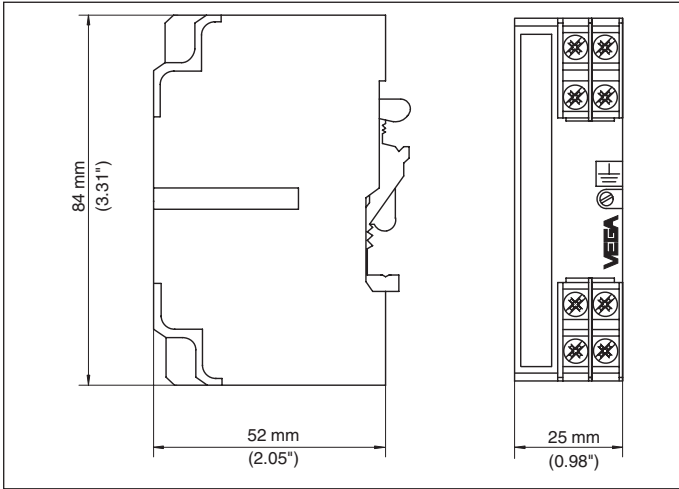

Fig. 12: Dimensions, overvoltage protection

Housing

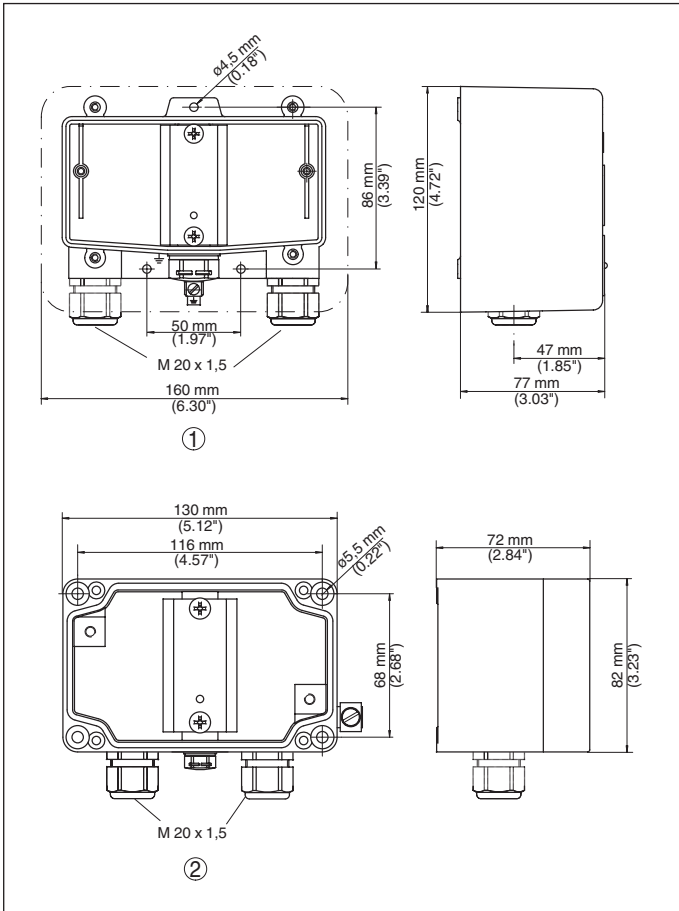

Fig. 13: Dimensions, housing

- 1 Plastic housing
- 2 Aluminium housing

Overvoltage arrester for mounting in sensor housing

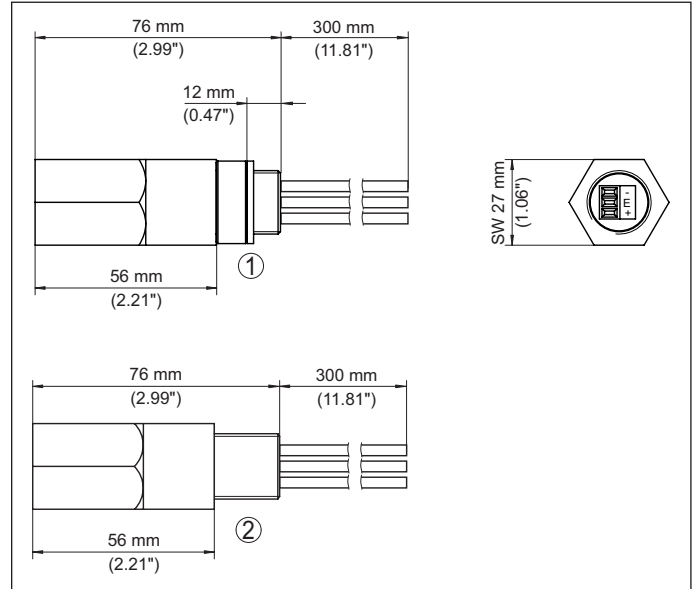

Fig. 14: Dimensions, overvoltage protection

- 1 Thread M20 x 1.5 or 1/2 NPT, depending on order specification

Overvoltage arrester for mounting on the sensor electronics

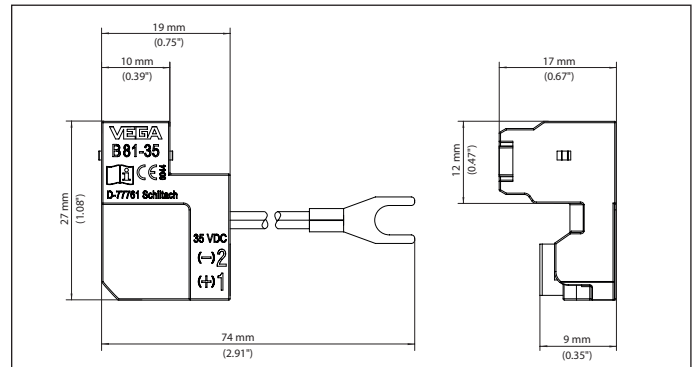

Fig. 15: Dimensions, overvoltage protection



All statements concerning scope of delivery, application, practical use and operating conditions of the sensors and processing systems correspond to the information available at the time of printing.
Subject to change without prior notice

© VEGA Grieshaber KG, Schiltach/Germany 2021

VEGA Grieshaber KG
Am Hohenstein 113
77761 Schiltach
Germany

Phone +49 7836 50-0
E-mail: info.de@vega.com
www.vega.com

VEGA

50707-EN-210817