

General Features

- The fully sealed liquid expansion in the system provides a self powered indication and operation to the instruments, and does not require any trimming or other periodic adjustments.
- Instruments are fully compensated for ambient temperature.
- The WTI instruments have a built in Thermal imaging system for transformer's hot spot indication.
- WTIs are calibrated & supplied suitable for range of CT secondary input & temperature rise.
- Instrument cases are aluminium die casted and polyester powder coated, and provided with projection mounting clamps.

As per enclosure part no. EN5.

- A maximum pointer facility is provided, can be reset from outside.
- All switch contacts are potential free micro switches.

Hybrid Models Contain

- **Embedded PT-100 sensor in the sensing bulb of the local OTI/WTI for master indication.**
- Current Converter Unit (CCU) is mounted inside the Local OTI/WTI, CCU output to be connected to our External PSU or Remote indicator unit.

General Standard Specifications

Temperature Range	0-150°C, Standard (other ranges on request)
Dial Size	150mm (6") Round
Dial angular Sweep	270°
Dial Graduation	1°C
Accuracy Class	±1% of FSD
Contacts	Upto 6 Normally open Contacts
Contact Rating	Standard Micro Switch 15A @ 250V AC or 0.5A @ 250V DC
Switching Range	15% - 85% of FSD
Switch Differential	S1& S2: 3°C to 9°C (6±3°C) Fixed S3 to S6: 8°C to 40°C Adjustable.
Switching Accuracy	±2.5°C of Set Value
Max. Capillary Length	Up to 25 Mtrs (Bottom Entry)
Switch Test Knob	Available
Electrical Connection	Press Fit Wago Type
Window Glass	UV Resistant Polycarbonate
Degree of Protection	IP – 55 (IEC - 60529 Cat -II)
Electrical entry	M20 Threaded Holes - 3Nos

MODEL 1005A/1005AH/1005AHX



MODEL 1005APS/1005AHPS/1005AHXPS



Hybrid Models Specification

Embedded Pt100 sensor	Upto 2 Sensors as per IEC 60751-1985/DIN 43760	
Built in CCU	CCU is mounted inside the Local OTI/WTI	
OTI	Signal input	Pt 100
	Supply input	24v Dc-through our make PSU/Remote indicator
For WTI	Additional Winding temperature simulator is provided inside the local WTI.	

Optional Spec

Temperature Range	0-160°C / 30-150°C / -20-140°C / other range on request
Contact Rating	Magnetic blowout Micro Switch 15A @ 250V AC or 5A @ 250V DC
Switch Configuration	Change over Contacts
Electrical Connection	Plug and Socket with IP of 65
Electrical Entry	PG 16 / adapter + M25 - 3 Nos
Cable Gland	Brass / polyamide / others on request
Thermometer Pocket	On request
Connector Type	½" / ¾" / 1" BSP M/F Brass / Aluminum Alloy
Ingress Protection	upto IP 66 IEC 60529
Capillary Entry	Top Entry
Switch Differential Adjust 8° C- 40° C	A: Normally Open Contacts upto 6 Switches B: Change over Contacts upto 5 Switches

Remote Indicator Options

Dial Type Thermometer Models	Suitable Digital Remote Indicator Models	Remote Indicator Signal Inputs
1005AH/1005AHPS/1005AHX/1005AHXPS Built in CCU	Model 2245H	Suitable Hybrid Model Connection from built-in CCU inside Local OTI/WTI
1005AH/1005AHPS/1005AHX/1005AHXPS Built in CCU and external PSU	Model 2245	Suitable for 4 - 20mA input from External PSU

Note: Refer Ordering information for various types of remote indicators

Remote Indicator General Specification

Type	Quad Seven segment LED display
Resolution	0.1°C
Auxiliary Supply input	90-260V AC/DC
Degree of protection	IP 20
Operating temperature	0-60°C
Mounting Cutout	92 sq.mm in panel, Mounting side clamp
Signal input	Suitable for connection from built-in CCU inside the Local OTI/WTI / External PSU
Signal output	Refer table below (Remote Indicator Output Options)
Power Consumption	5 Watts



Remote Indicator 96 Sq

PSU Spec

Signal input	Suitable for connection from built-in CCU inside Local OTI/WTI
Auxiliary supply input	90-260v AC/DC
Signal Output	2Nos. 4-20mA DC
Burden on signal outputs	Maximum 600Ω including loop resistance
Mounting	Din rail or Screw fixing
Degree of protection	IP 40 for housing & IP 10 for terminals
Power Consumption	3Watts

PSU



Note: Available Scheme options referenced below. Please contact us for details.

1. Standard (1005A)
2. Hybrid and External Remote Indicator (1005AH + RI / 1005AHX + RI / 1005AHPS + RI / 1005AHXPS + RI)
3. Hybrid and External PSU (1005AH + PSU / 1005AHX + PSU / 1005AHPS + PSU / 1005AHXPS + PSU)
4. Hybrid & External PSU + Remote Indicator (1005AH + PSU + RI / 1005AHX + PSU + RI / 1005AHPS + PSU + RI / 1005AHXPS + PSU + RI)

Routine and Type Tests Conducted

- 1 Routine test : HV Test and IR Test and Calibration Test
- 2 Protection class:
IP55 as per IEC 60529 CAT II.
IP66 as per IEC 60529
- 3 Cold Test: -40°C as per IEC 60068-2-1
Dry Heat Test: + 70°C as per IEC 60068-2-2
- 4 Vibration Test: as per IEC 60068-2-6
Displacement : 0.15mm,
Frequency: 10-55Hz,
Duration: 1hr. 20min/X,Y,& Z axis
- 5 Salt Spray Test:
For polyester powder coating and
SS 304 Armour for 500 Hrs as per
DIN 50021 Standard
- 6 Micro Switch rating Test:
 - a) 15A @ 250V AC &
0.5A @ 250V DC
 - b) 15A @ 250V AC &
5A @ 250V DC

Basic Ordering Information

Select Your Model	<ul style="list-style-type: none"> • Standard -1005A • with 1 inbuilt PT 100 Sensor (Simplex) & CCU - 1005AH • with 2 inbuilt PT 100 Sensor (duplex) & CCU - 1005AHX • with PS (1005APS, 1005AHPS, 1005AHXPS) 	
Switch Contact Rating	OP1 - Option 1 - Standard Micro Switch OP 2 - Option 2 - Magnetic Blowout Micro Switch	
Type of Instrument	OTI/WTI	
Range	R1.0 - 150°C R2.0 - 160°C R3.30 - 150°C R4. -20 to 140°C (other ranges on request)	
No. of Switches	S2 -2switches S3 -3switches.....upto S6 switches	
Switch Configuration	L- Normally open contact L2 - Changeover contact	
Capillary Length	C3 - 3 mtrs	C5 - 5 mtrs
	C8 - 8 mtrs	C10 - 10 mtrs
	C12 - 12 mtrs	C15 - 15 mtrs
	C20 - 20 mtrs	C25 - 25 mtrs
Union Type	U1 - ½" BSP Male U2 - ¾" BSP Male U3 - 1" BSP Male U4 - ½" BSP Female U5 - ¾" BSP Female Other threads on request	
Indicator	RI - Remote Indicator (for options please see Note below)	
If WTI please specify	Transformer CT Secondary output Simulated Temperature rise over top oil Contact Precimeasure for gradient graph	

Note:

Remote Indicator	Options T1 - Indication only. T2 - 2Nos, 4-20mA DC outputs. T3 - one 4-20mA DC output + 2Nos. Change over relay contacts T4 - one 4-20mA DC output + RS 485 Modbus RTU protocol T5 - 4Nos. of 4-20mA DC outputs.
------------------	---

Note: WTI Gradient calibration is factory set as per customer specification. If required, a provision is made for small adjustment at site.

Sample Ordering Information : 1005A\OP1\WTI\R1\S4\L2\C6\U1\RI-T1\.....Amps oC

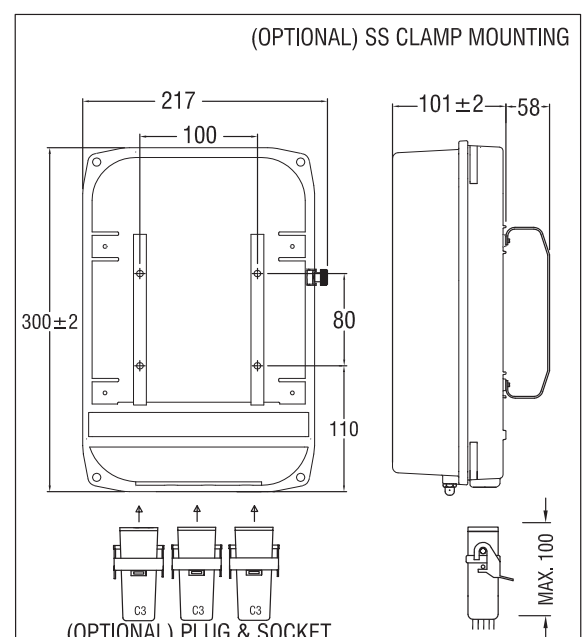
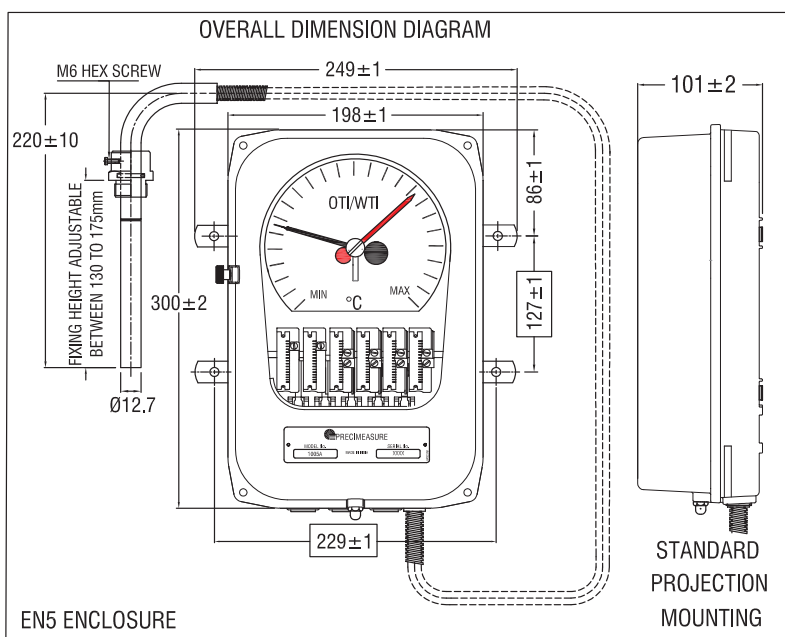

SCHEMATIC CONNECTION DIAGRAM FOR (SIMPLEX OR DUPLEX) HYBRID INSTRUMENTS.

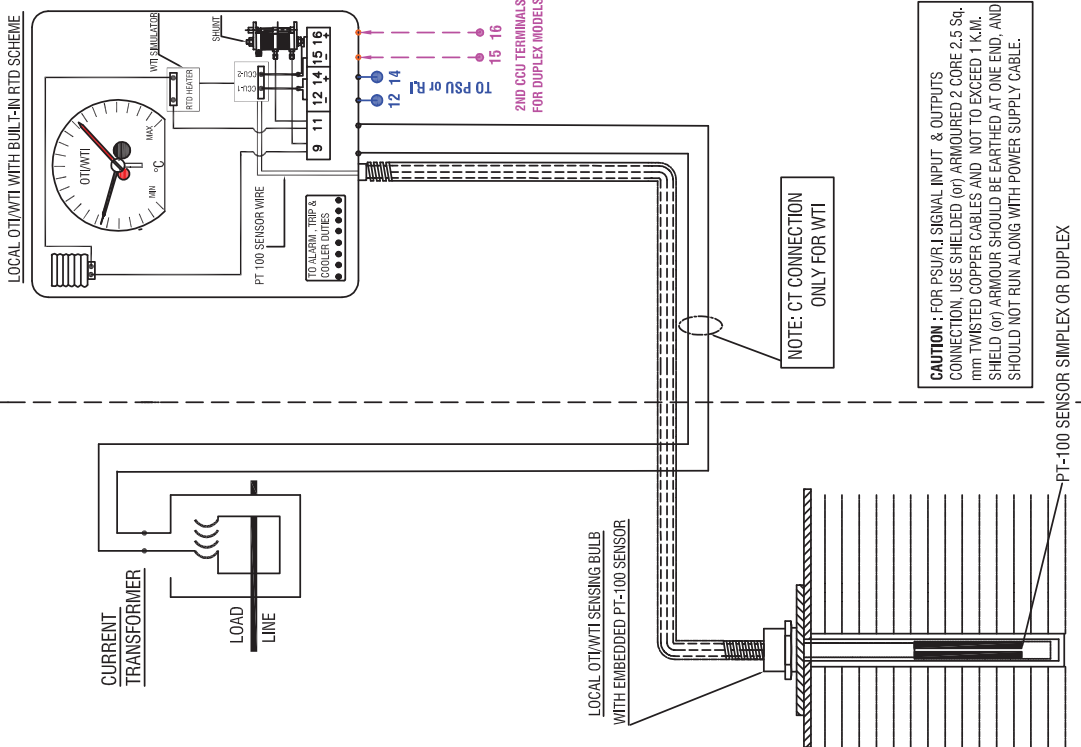

TRANSFORMER

EN5 ENCLOSURE

LOCAL MARSHALLING BOX KIOSK

HYBRID OPTION - 1 EXTERNAL REMOTE INDICATOR

MODEL: 2245H-T2

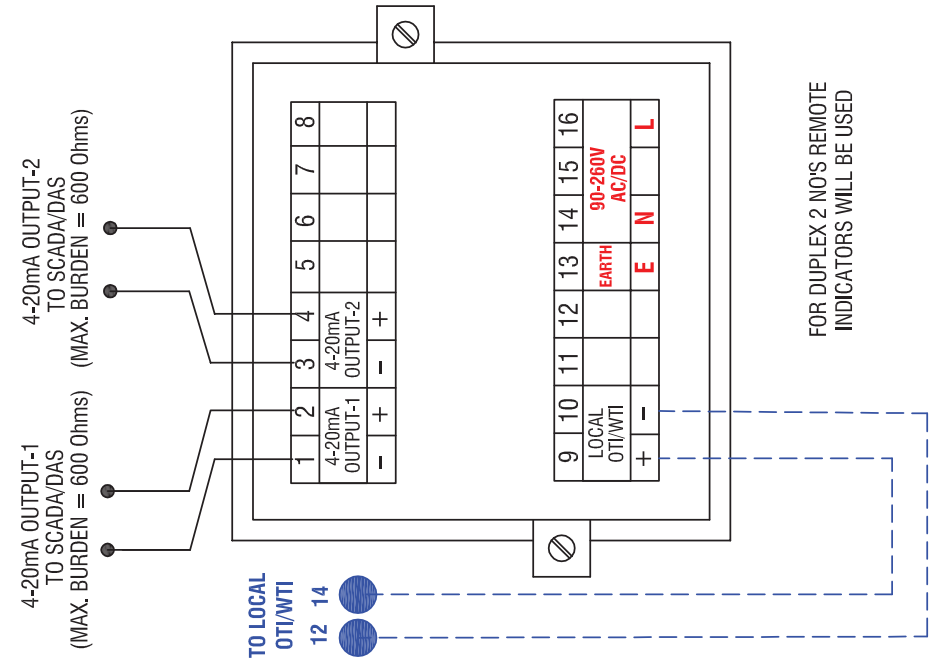

REMOTE CONTROL PANEL

HYBRID OPTION - 2 EXTERNAL POWER SUPPLY UNIT

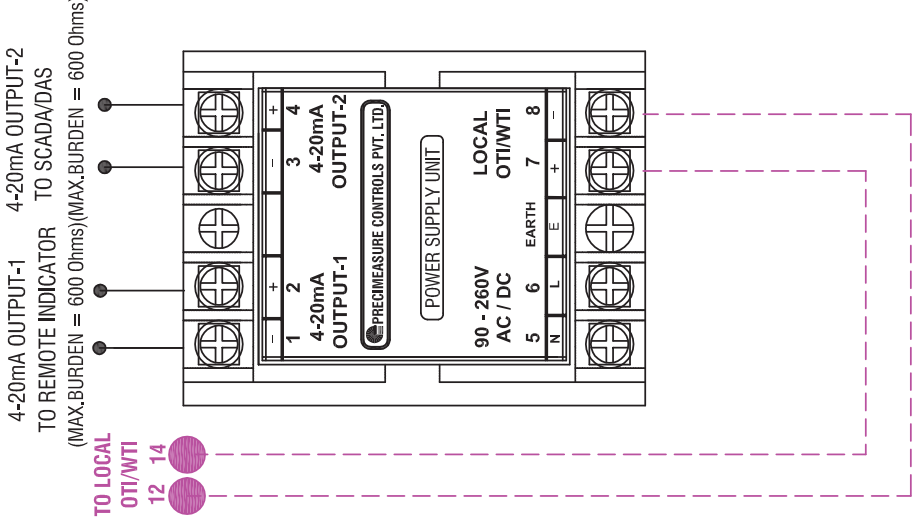

LOCAL MARSHALLING BOX KIOSK